

Electron Energy and Light

How does light reveal the behavior of electrons in an atom?

Why?

From fireworks to stars, the color of light is useful in finding out what's in matter. The emission of light by hydrogen and other atoms has played a key role in understanding the electronic structure of atoms. Trace materials, such as evidence from a crime scene, lead in paint or mercury in drinking water, can be identified by heating or burning the materials and examining the color(s) of light given off in the form of bright-line spectra.

Model 1 – White Light

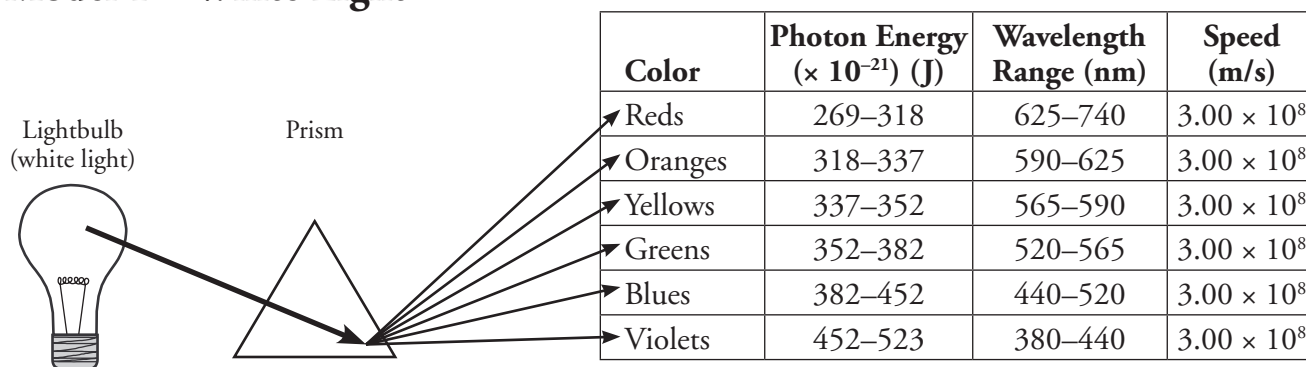

1. Trace the arrows in Model 1 and shade in the table with colored pencils where appropriate.
2. What happens to white light when it passes through a prism?
3. Why are the color labels in the table in Model 1 plural (*i.e.*, “Reds” rather than “Red”)?
4. Do all colors of light travel at the same speed?
5. Do all colors of light have the same energy? If no, which colors have the highest energy and the least energy, respectively?
6.  Consider the light illustrated in Model 1.
 - a. Which color corresponds to the longest wavelengths?
 - b. Which color corresponds to the shortest wavelengths?
 - c. Write a sentence that describes the relationship between wavelength and energy of light.



Model 2 – Emission Spectra for Hydrogen and Boron Atoms

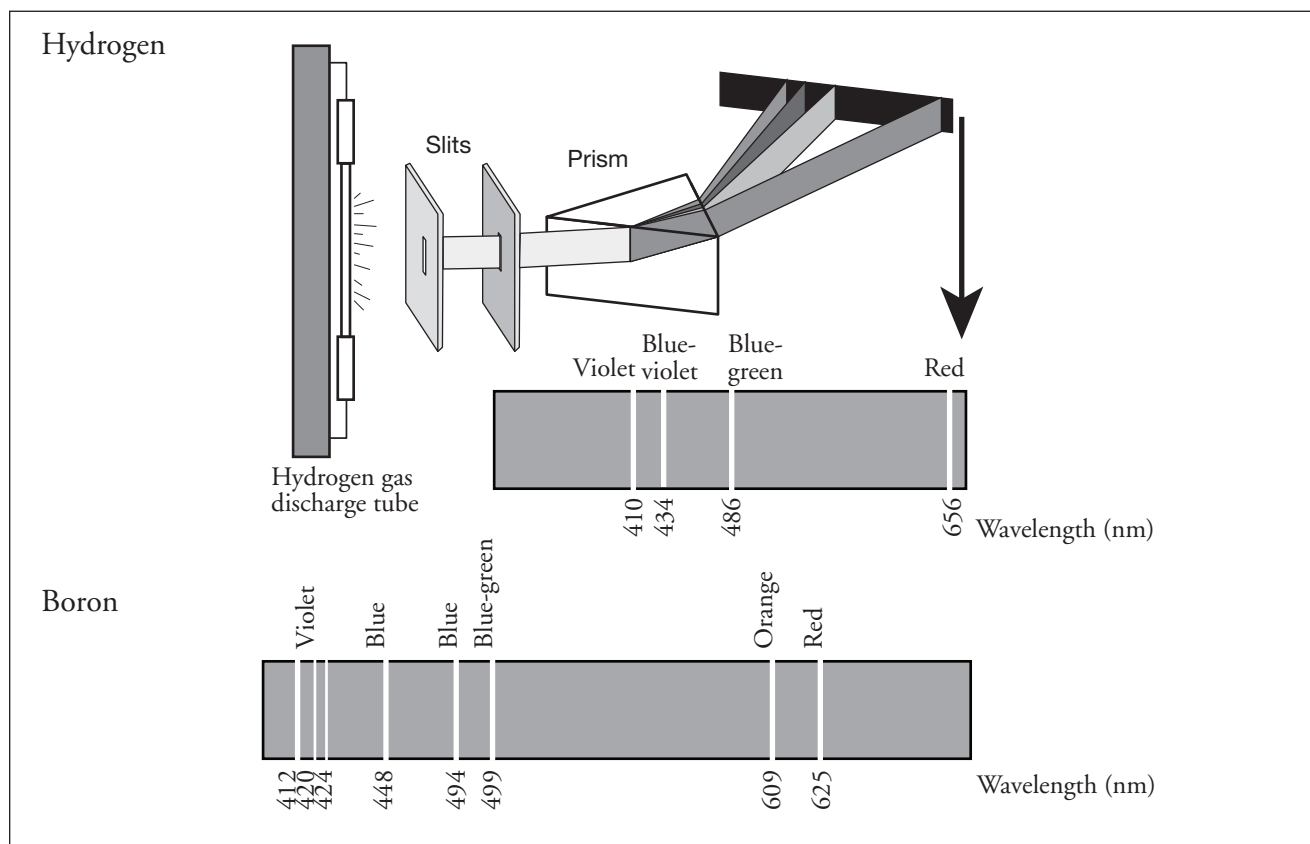

- Use colored pencils to color the hydrogen and boron spectral lines within their respective spectra in Model 2.
- List the spectral lines for hydrogen gas by color and corresponding wavelength.
- The spectral lines for boron were produced using the same method as hydrogen. List three of the colors and corresponding wavelengths for boron's spectral lines as its light passes through a prism.
- Consider the hydrogen spectrum in Model 2.
 - Which color of light corresponds to the shortest wavelength?
 - Which color of light corresponds to the longest wavelength?

11. Consider the hydrogen spectrum in Model 2.
 - a. Which color of light has the most energy?
 - b. Which color of light has the least energy?

12. Does a gas discharge tube filled with boron emit the same wavelengths of light as a tube filled with hydrogen? Use evidence from Model 2 to support your answer.

13. “The spectral lines for atoms are like fingerprints for humans.” How do the spectral lines for hydrogen and boron support this statement?

Circle the appropriate word to complete each statement in Questions 14–17.

14. Electrons and protons (attract/repel) each other.
15. As an electron gets closer to the nucleus the (attraction/repulsion) to the nucleus gets (stronger/weaker).
16. For an electron to move from an energy level close to the nucleus to an energy level far from the nucleus it would need to (gain/lose) energy.
17. For an electron to move from an energy level far from the nucleus to an energy level close to the nucleus it would need to (gain/lose) energy.



Read This!

Niels Bohr modified Rutherford’s Nuclear Atom model to explain how light interacted with the electrons in an atom to produce spectral lines. His model included electrons orbiting the nucleus at specific energy levels. Electrons absorb energy from various sources (electricity) when they move from lower energy levels (ground state) to higher energy levels (excited states). Energy is released as electrons return to their lower energy levels.

18. Is energy absorbed or released for the electron transition shown in the diagram to the right? Explain.

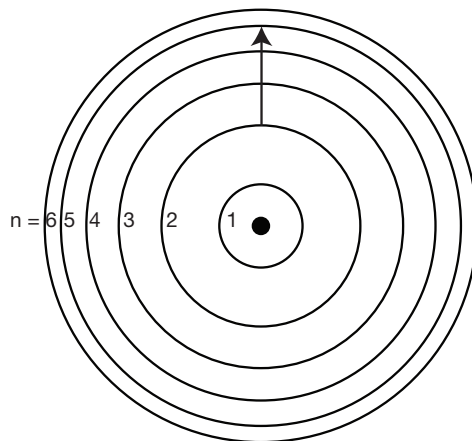

Model 3 – Bohr Model of a Hydrogen Atom

A. _____

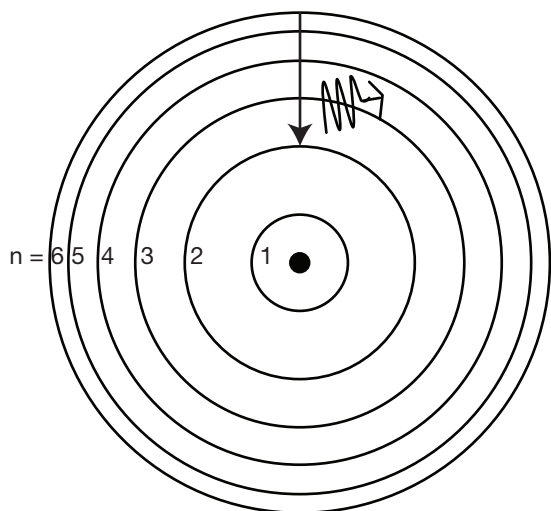

B. _____

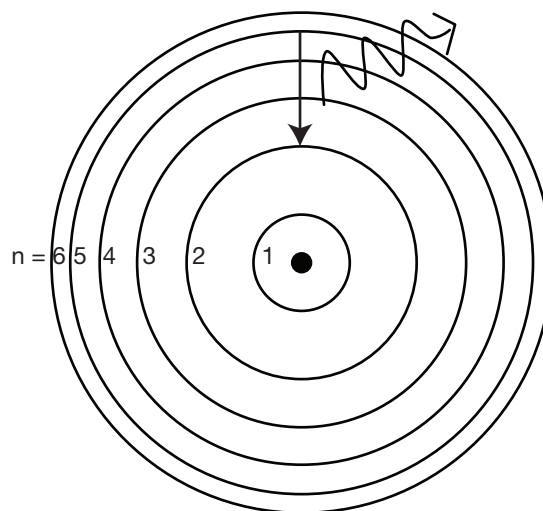

C. _____

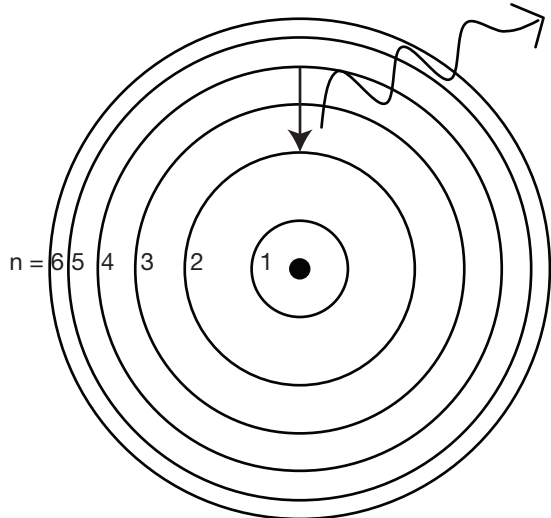

D. _____

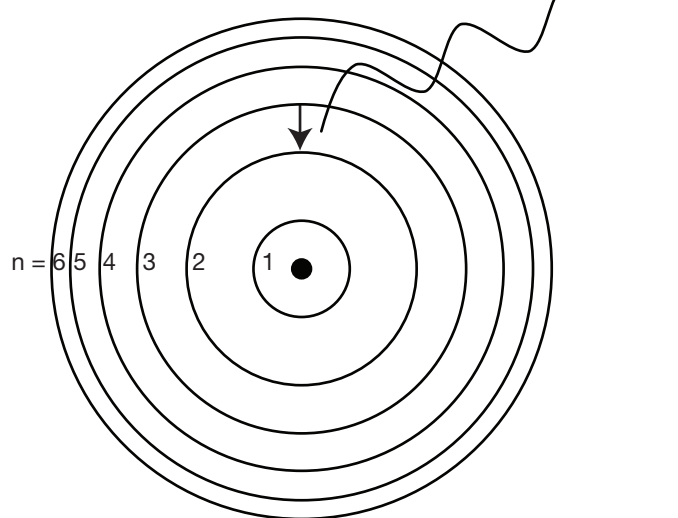

19. Identify the drawing in Model 3 that depicts a hydrogen atom with an electron moving from energy level 5 to energy level 2. Refer to Models 1 and 2 for the following questions.
- Label the picture with “ $n=5$ to $n=2$ ” and list the corresponding color of light emitted.
 - This electron transition (absorbs/releases) energy.
 - This electron moves from a (lower/higher) energy state to a (lower/higher) energy state.
 - Is light absorbed or released in the electron transition?

20. Label the remaining drawings in Model 3 with the electron transitions that are occurring ($n=?$ to $n=?$), the wavelengths and corresponding colors as given in example A in Model 3. See Model 2 in order to identify the color of spectral lines produced in each of the hydrogen atom electron transitions shown in Model 3. Use colored pencils to trace the light wave in each of the four pictures with the appropriate color.
21. Consider the electron transitions in Model 3.
- Which of the electron transitions involves the most energy?
 - Explain why this transition involves the most energy based on your understanding of the attractive forces between the electrons and protons in the atom.
22. Explain why a single atom of hydrogen cannot produce all four hydrogen spectral lines simultaneously.
23. If Question 22 is true, how can we see all four colors from a hydrogen gas discharge tube simultaneously?

Extension Questions

24. The hydrogen spectral lines in Model 2 are only the wavelengths of light that are in the visible range and therefore “seen” by the naked eye. However, many other wavelengths can be detected with special equipment.
- Propose a hydrogen electron transition that involves light with a wavelength in the ultraviolet (UV) range (10–400 nm).
 - Propose a hydrogen electron transition that involves light with a wavelength in the infrared (IR) range (1000–106 nm).

25. Below are diagrams for the bright line spectra of four elements and the spectrum of a mixture of unknown gases.

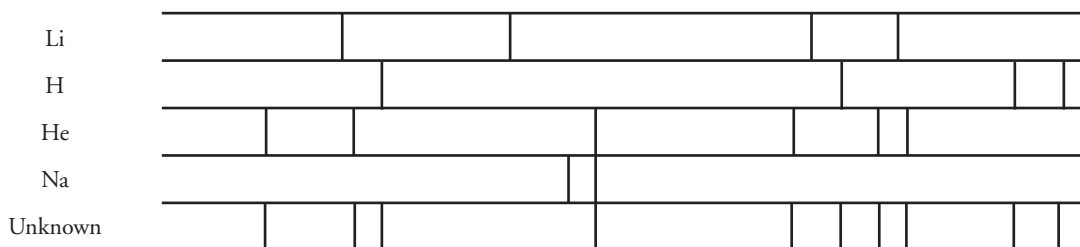

- Which element(s) are not present in the Unknown?
 - Which element(s) are in the Unknown?
26. Model 2 shows the emission spectra for hydrogen and boron. Scientists can also record the absorption spectra for elements. Propose how this might be done, and what the absorption spectra of hydrogen and boron would look like.